

A
B
C
D
E
F
G

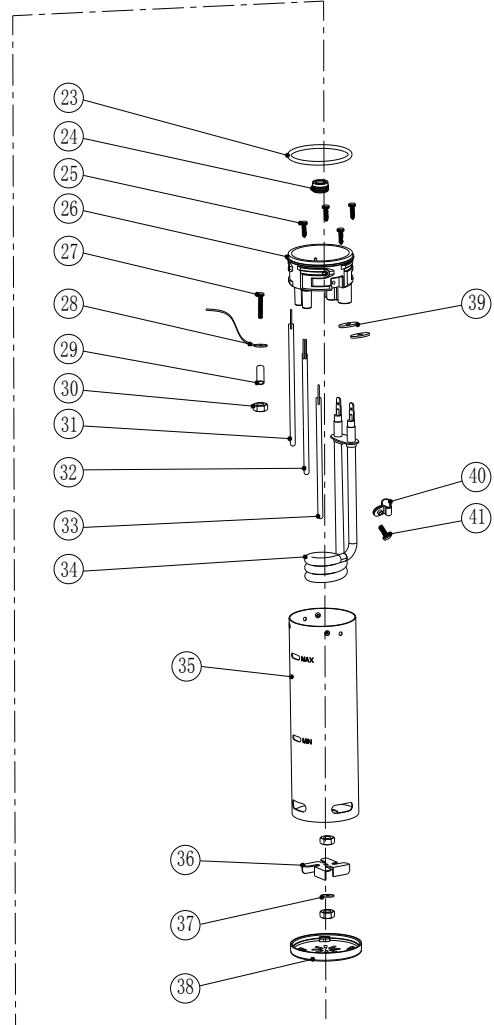
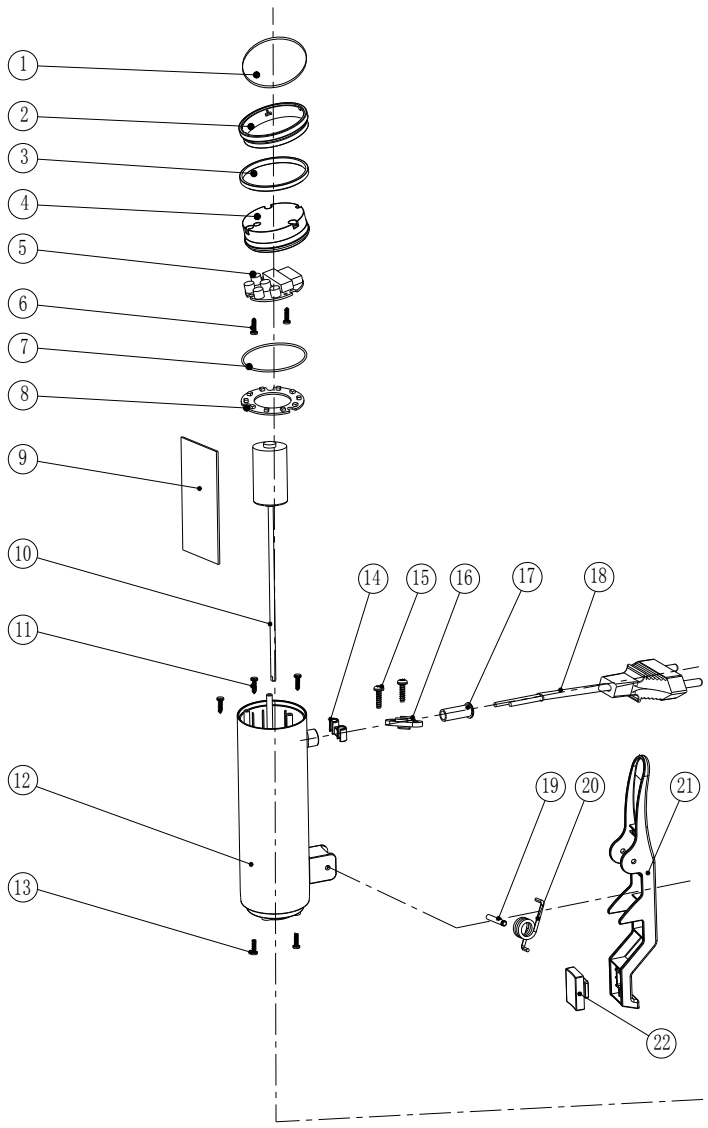

37		spring washer	2	φ 4.0, SUS304	
36	SV610-80-02	water mixer	1	T=0.8, SUS304	
35	SV610-80-01	ss housing	1	φ 54.0MM*165MM, T=0.7	A
34	SV610-60-03	heating tube	1	220-240V/50Hz/1200W	A
33		anti dry probe	1	φ 4.0, 145度, SUS304	
32		temperature probe	1	φ 4.0, 10K, SUS304	
31		water level probe	1	φ 4.0, SUS304	
30		screw	3	M4.0, SUS304	
29	SV610-80-05	steel cover	1	φ 5*φ 4. *19.5, SUS304	B
28		ground ring terminal	1	φ 4镀锌	B
27		screw	1	M4*25正牙, SUS304	
26	SV610-10-03	heating bracket	1	PA66	
25		screw	4	PA3.0*12	
24	SV610-20-05	shaft sealing ring	1	橡胶, 35-45°	
23	SV610-20-04	stand sealing ring	1	硅胶本色30-40度	C
22	SV601-20-02	Handle clamping block	1	硅胶黑色40-50度	C
21	SV601-10-06	handle	1	ABS黑色	
20	SV610-80-04	handle spring	1	φ 2.5, SUS304	
19	SV610-80-03	handle bracket	1	φ 4.0, SUS304	
18	SV610-60-02	cabel	1	VDE三插, HO5VV-F	D
17	SV610-20-01	Tail sleeve	1	硅胶黑色40-50度	D
16	CP101-80-04	cord clamp	1	PC黑色	
15		screw	2	PWA3.0*14, 镀镍	
14	SV601-10-05	pressure line bracket	1	ABS本色	
13		screw	6	M2.5*5正牙, 镀镍	
12	SV601-10-03	housing	1	ABS+PC	E
11		screw	3	PWA2.6*12	锁面盖
10		dc motor	1	12V, 2200RPM	
9		pcb board	1	220-240V, 50Hz	
8		pcb light	1	220-240V, 50Hz	
7	SV601-20-01	sealing ring	1	硅胶红色30-40度	
6		screw	2	PA2.6*8, 铁镀镍	锁PCB按键板
5		pcb panel	1	120V, 60Hz	F
4	SV601-10-01	panel cover	1	ABS透明	
3	SV601-10-04	LED light	1	ABS本色	
2	SV601-10-02	cap decoration	1	ABS本色电镀	
1	SV601-20-08	panel	1	亚克力, T=1.0MM	
序号	图号	名称	数量	材质/规格	备注

41		螺钉	1	PWM4.0*8, SUS304	
40		卡夹	1	SUS304, T=0.6MM	
39		O型密封圈	2	硅胶本色, 35-45度	
38	SV610-10-04	底座	1	PA66	
序号	图号	名称	数量	材质/规格	备注

				MODEL NO.:	SPEC: 220-240V/50Hz/1200W	
				PART NAME:		
APPROVED BY:	CHECKED BY:	DRAWN BY:	DATE:	MATERIAL:	PROJ.:	SCALE:
					SHEET OF	VER.